

Rugged high performance XMC Graphics Module

Key Features

The Condor NVP2102AxX is a rugged high performance XMC graphics card that captures both analog and digital raw frame-by-frame audio/video and metadata with exceptionally low latency. This all-in-one solution provides the ability to simultaneously capture, process, display, encode, decode, and stream video data while

- Supports a wide range of inputs and outputs (3G-SDI, DVI, DisplayPort...)
- SDI VANC KLV metadata insertion/extraction supported
- Designed for applications that combine legacy video with newer digital video formats
- Using NVIDIA® supporting CUDA® and OpenCL based GPGPU computing, AI processing, deep learning and H.265/H.264 encoding and decoding.
- GPUDirect™ RDMA

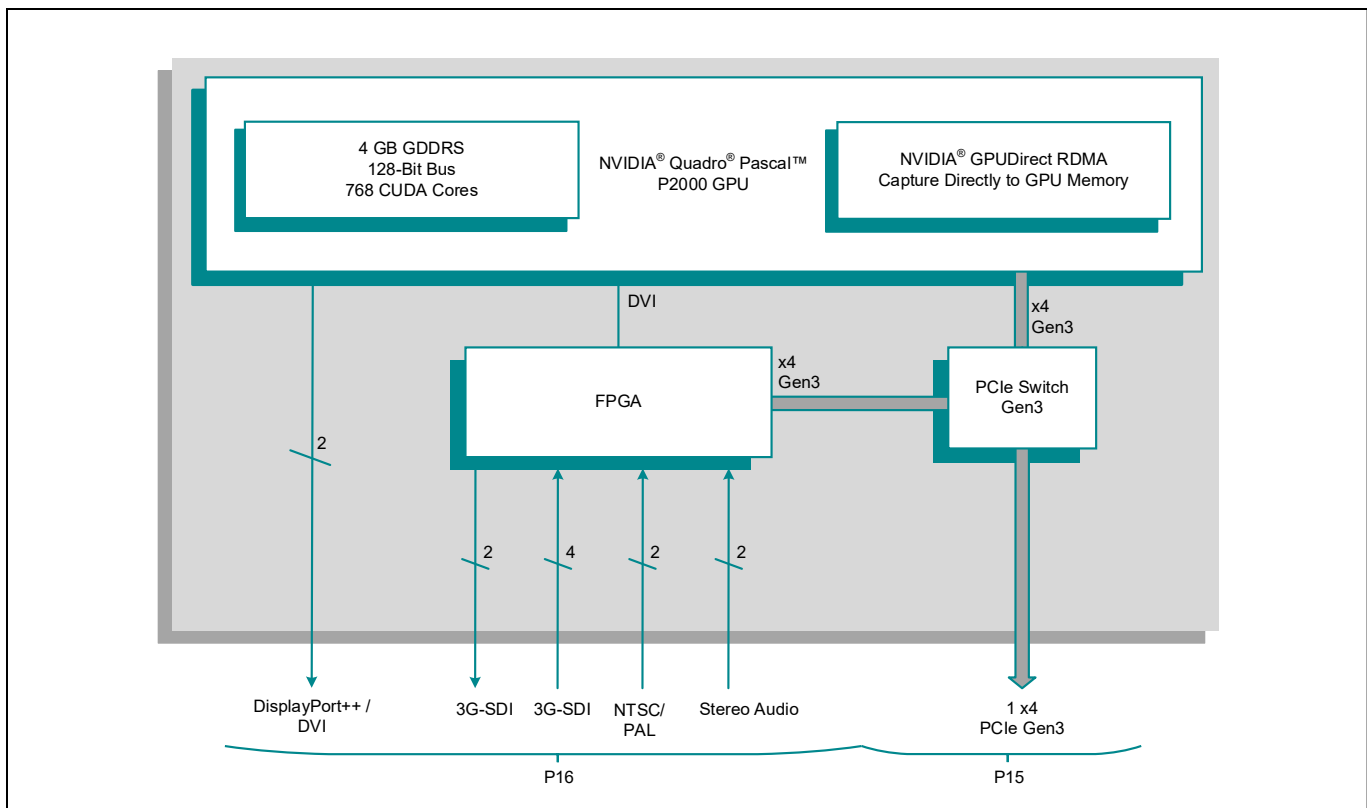

Graphics Processor

- NVIDIA® Quadro® Pascal™ P2000 GPU (Chip-down GP107)
- supports Microsoft® DirectX 12 and OpenGL 4.5

Graphics Memory

- 4 GB GDDR5
- 128-bit Memory Interface
- 96 GB/s Memory Bandwidth

XMC Interface

- x4 PCIe interface:
 - supports Gen1, Gen2 and Gen3
- XMC 1.0 or XMC 2.0

Audio/Video

- video outputs:
 - 2x 3G-SDI capable of a resolution up to 1080p60
 - 2x DVI/DisplayPort capable of resolutions up to 3840 x 2160 @ 60 Hz
 - Rear Pn6 XMC I/O. VITA 46.9 x12d+x8d+24s
- video inputs:
 - 4x 3G-SDI (support up to 1080p60)
 - 2x CVBS (NTSC/PAL)
 - Rear Pn6 XMC I/O. VITA 46.9 x12d+x8d+24s
- audio inputs:
 - 2x Stereo Line In

GPGPU Capabilities

- 768 CUDA® Cores
- up to 2.3 TFLOPS FP32 Single Floating Point Performance
- supports CUDA 10 (Compute Capability 6.1)
- OpenCL 1.2 and Shader Model 5.1
- H.265 (HEVC) / H.264 (MPEG4/AVC) Hardware Encode and Decode
- NVIDIA® GPUDirect™ RDMA, NVENC, NVDEC

Software

- supports Windows® and Linux®

Electrical Specification

- power consumption : 35 W (application dependant)

Environmental Specification

- conduction-cooled operating temperature (RC-Series):
 - MIL-STD-810, -40°C to +85°C
- non-operating temperature:
 - MIL-STD-810, -55°C to +105°C
- 5% to 95% Relative Humidity, non-condensing:
 - includes Hysol PC18M conformal coating

Mechanical Specification

- operating mechanical :
 - shock – MIL-STD-810, 40 g
 - vibration – MIL-STD-810, 0.1 g²/Hz
- single size CMC (Common Mezzanine Card)
74 mm x 143.75 mm
- 10 mm height stack module



Parhelia B.V.
www.parheliabv.com
☎ +31(0)10 741 00 28