

## Rugged 3U VPX™ I/O Intensive Plug In Card (PIC) based on 13<sup>th</sup> Generation Intel® Core™ Series Processor

### Key Features

Hermes is a rugged 3U VPX™ Plug In Card (PIC) based on the 13<sup>th</sup> Gen Intel® Core™ Processor for general purpose computer applications. It is designed in alignment with the SOSA™ Technical Standard for I/O intensive processor PICs.

- 14-core processor for high performance
- 100GBASE-KR4 Ethernet Data plane
- x4 Gen 4 PCI Express® Expansion plane for high speed communication with adjacent board(s)
- XMC Site for additional I/O resources
- Optional M.2 module for storage with Write Protect and Opal 2.0 compliance
- Rugged conduction-cooled and Air Flow Thru versions available

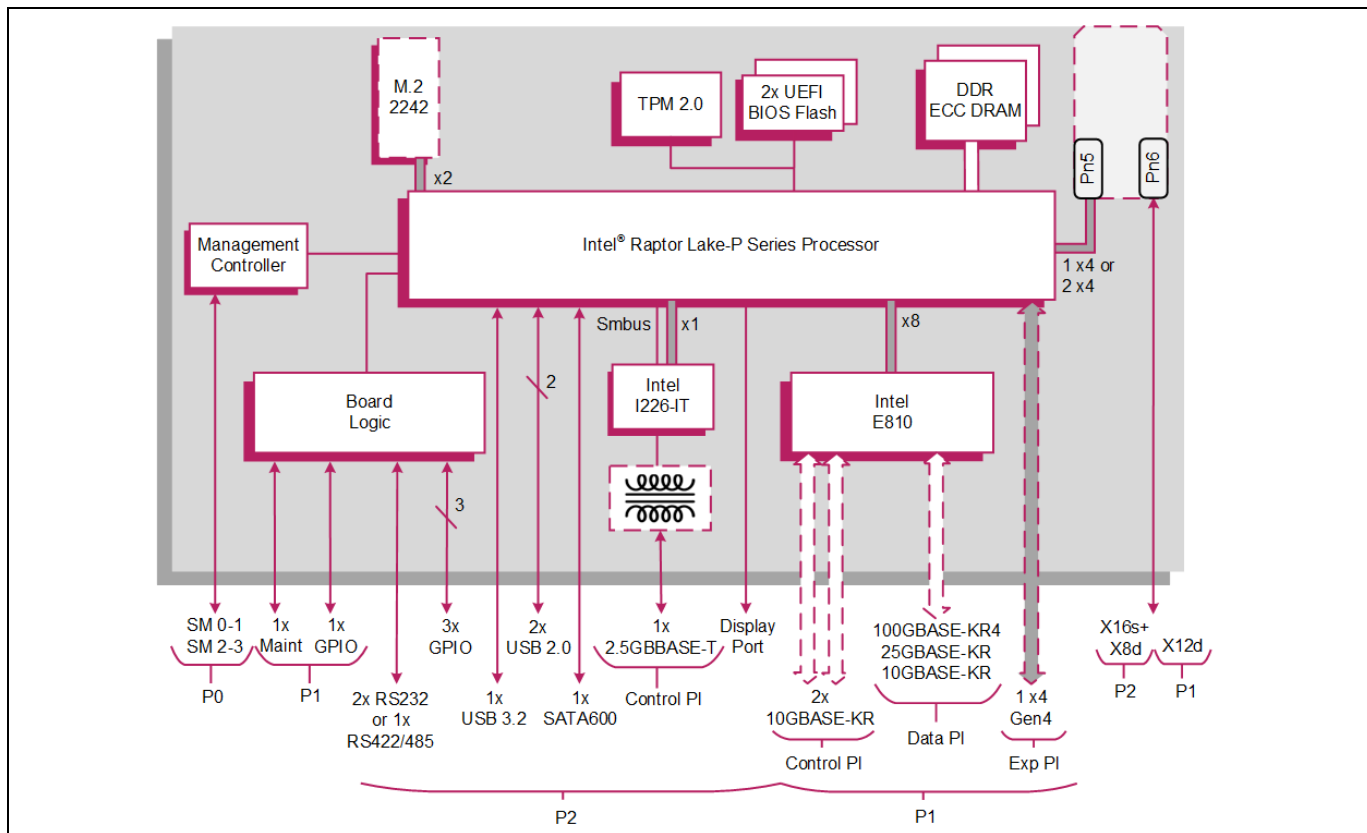

## VPX Processor PIC

- rugged conduction-cooled 3U VPX™ PIC based on 13th Generation Intel® Core™ Series Processor
- compliant with two OpenVPX™ module profiles:
  - SLT3-PAY-1F1F2U1TU1T1U1T-14.2.16
  - MOD3-PAY-1F1F2U1TU1T1U1T-16.2.15-4

## Central Processor

- 14-core Intel® Core™ i7-13800HRE Processor
- Intel Vector Neuro Network Instructions (VNNI)
- Intel® Iris® Xe (Gen 12) Graphics Engine with up to 96 EUs

## DRAM

- 64 Gbytes soldered LPDDR5 IB ECC DRAM:
  - in-band ECC
  - single bit error correction

## Optional XMC Site

- 1x XMC site, in a single VPX slot (VITA 42.0):
  - XMC rear I/O, providing X12d+x16s+x8d
  - 1 x4 or 2 x4 PCI Express® (PCIe®)
  - PCIe Gen 1, Gen 2 and Gen 3
- XMC connector type (build option):
  - VITA 42 XMC (black color)
  - VITA 61 XMC 2.0 (white color)
- XMC VPWR +12 V
- VITA 46.9 XMC I/O pin-out

## Serial Ports

- 1x RS232/422/485 port accessed via P2
- 1x maintenance port accessed via P1
- Maintenance port on P1 supports LVCMOS levels
- 16550 compatible UARTs

## Graphics/Audio Interfaces

- 1x graphics/audio interface:
  - DisplayPort™ v1.2 interface, supporting audio and video, via P2
  - up to 3840 x 2160 @ 60 Hz, driver dependent

## Other Peripheral Interfaces

- PC RTC, long duration timer, watchdog timer
- 2x USB 2.0 and 1x USB 3.2 (Gen 1) ports via P2
- 3x GPIO signals via P2
- 1x GPIO signal via P1

## Mass Storage Interfaces

- 1x SATA 600 via P2
- 1x M.2 SSD site supports:
  - 2242 format module
  - x2 PCIe interface (M-key)
  - Opal 2.0 security encryption
  - Write Protect
  - NVMe Express® (NVMe®) logical device interface

## VPX Control Plane, Ethernet

- configurable Control Plane (VITA 46.6)
- 1x 2.5GBASE-T Ethernet port via P2:
  - supports 10/100/1000/2.5GBASE-T
  - option for with or without magnetics
  - implemented by Intel Ethernet Controller I226-IT
  - TSN support
- up to 2x 10GBASE-KR Ethernet ports via P1 (VITA 46.7):
  - supports up to 2x 10GBASE-KR
  - implemented by Intel® Ethernet Controller E810 via x8 PCIe
  - factory build option available to disable Control Plane
- supports IEEE 1588 Precision Time Protocol

## VPX Data Plane, 100 Gigabit Ethernet

- configurable Ethernet VPX Data Plane fabric interface (VITA 46.7)
- 1x 100 Gigabit Ethernet port via P1 (VITA 46.7):
  - supports 1x 100GBASE-KR4 or 1x 25GBASE-KR or 4x 10GBASE-KR
  - implemented by Intel Ethernet Controller E810 via x8 PCIe
  - factory build option available to disable Data Plane
- supports IEEE 1588 Precision Time Protocol

## VPX Expansion Plane, PCI express

- configurable PCI Express (PCIe) VPX Expansion Plane fabric interface (VITA 46.4):
  - 1 x4 Gen 4
  - factory build option available to disable Expansion Plane
- PCIe interfaces support Gen 1, Gen 2, Gen 3 and Gen 4

## Optional Built-In Test (BIT) Support

- Power-on BIT, Initiated BIT, Continuous BIT

## System Management

- VITA 46.11 IPMC on-board controller:
  - SMO-1 and SM2-3
  - CPU temperature and voltage monitor accessed via System Management interface
- option for VITA 46.11 compatible Tier 1 Chassis Manager

## Board Security Packages

- Trusted Platform Module (TPM 2.0)
- supports Total Memory Encryption, ROP Attack Prevention and Advanced Crypto-Key Protection
- option for Sanitization Utility Software Package
- option for proprietary board-level security features

## Software Support

- supports Linux® and Windows®

## Firmware Support

- dual 32 Mbyte BIOS SPI Flash EPROMs
- UEFI boot firmware (BIOS):
  - UEFI 2.7 support
  - implements Secure Boot
- implements Intel Boot Guard
- optional Fast Boot solution using the Intel Firmware Support Package (FSP)
- LAN boot firmware included

## Safety

- PCB (PWB) manufactured with flammability rating of UL94V-0

## Electrical Specification (Estimated)

- typical current figure for Intel® Core™ i7-13800HRE Processor with 64 Gbytes DRAM:
  - +12 V VS1 @ 3.8 A
  - +3.3 V AUX @ 0.4 A
- +12 V AUX and -12 V AUX routed to XMC site
- +5 V and +3.3 V are not connected

## Environmental Specification

- conduction-cooled (VITA 48.2)
- operating temperature at card edge:
  - VITA 47 Class CC3, -40°C to +70°C (RCx-Series)
- non-operating temperature:
  - VITA 47 Class C4, -55°C to +105°C
- operating altitude:
  - -1,500 to 60,000 feet (-460 to 18,300 meters)
- rapid decompression:
  - from 8,000 to 60,000 feet (from 2440 to 18,300 meters)
- relative humidity: 5% to 95%, non-condensing

## Mechanical Specification

- 3U VPX form-factor (VITA 46.0, VITA 48.0)
- 3.9-inches x 6.3-inches (100 mm x 160 mm)
- slot width (VITA 48.0):
  - 1.0-inch VPX-REDI Type 1, RCR-Series, Type 1 Extended Covers Two Level Maintenance (VITA 48.2)
- connectors to VITA 46.0 for P0, P1 and P2
- operating mechanical:
  - shock - VITA 47 Class OS2, 40 g
  - random vibration - VITA 47 Class V3, 0.1 g<sup>2</sup>/Hz



**Parhelia B.V.**

[www.parheliabv.com](http://www.parheliabv.com)

☎ +31(0)10 741 00 28